

PRODUCTION SHEET



aracne

ADVOCATING THE ROLE OF SILK ART AND CULTURAL HERITAGE AT NATIONAL AND EUROPEAN SCALE

It's the partially attached external handles and the spacious pocket that make this shopper the perfect companion for those who love the outdoors, the sea, the pool, or fitness - without giving up the natural elegance of silk.

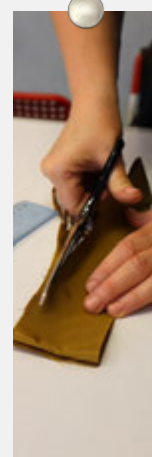

#821181



#E6900E



#AEBB8F

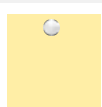

#FFEEA6

SILK SHOPPER 2

Design by

Prof. Sonja Šterman and Andreja Rudolf
University of Maribor - Faculty of Mechanical Engineering
Chair of Textile Materials and Design

Production coordinated by

Carmela Amodeo - EVAlab - EVA social cooperative



aracne

ADVOCATING THE ROLE OF SILK ART AND CULTURAL HERITAGE AT NATIONAL AND EUROPEAN SCALE

A bag with side part and a pocket

A four-season shopper bag that nods to outdoor living and fitness.

Its standout feature? The **handles** - sewn along the full length of the bag's sides. On the side that rests against the body, the stitching runs the entire edge of the handles. On the outer side, however, **the handles are only partially attached**.

This **clever loose space** can easily hold a rolled-up towel for the beach or pool, a yoga mat, or even a light sweater or shawl for when temperatures drop.

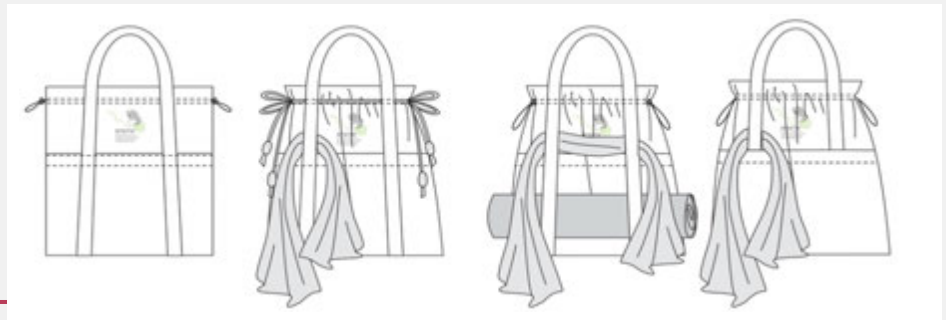
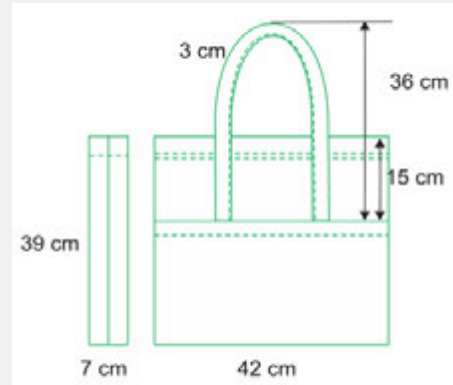

Short handles



Long handles



Different closures

String, elastic cord, ribbon made from the same fabric as the bag

SILK SHOPPER 2



Design by

Prof. Sonja Šterman and Andreja Rudolf
University of Maribor - Faculty of Mechanical Engineering
Chair of Textile Materials and Design

Production coordinated by

Carmela Amodio - EVA lab - EVA social cooperative



aracne

ADVOCATING THE ROLE
OF SILK ART AND CULTURAL
HERITAGE AT NATIONAL
AND EUROPEAN SCALE

**San Leucio silk
inside out**

The version created in the EVA lab workshop, during the training organised by the University of Maribor, adds yet another unique touch: it's made of **San Leucio silk**, using both **the front and back of the fabric!**

This precious damask fabric is known for its striking contrast between the outer side - typically adorned with **elegant floral designs** - and the inner side, where vibrant colored threads weave into **fascinating abstract patterns**.

In this shopper, the inner side of the San Leucio silk used for the bag is **turned outward** to create a decorative band offering an unexpected and eye-catching visual twist.

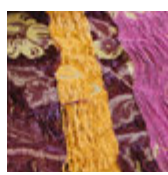
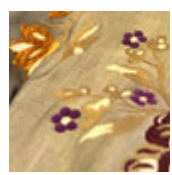

SILK SHOPPER 2



SILK SHOPPER 2



aracne

ADVOCATING THE ROLE OF SILK ART AND CULTURAL HERITAGE AT NATIONAL AND EUROPEAN SCALE



STEP 1 Pattern making

In this phase, the initial sketch is analysed and translated into a pattern.

The technical process involves **outlining the perimeter** of each individual component of the bag design, accurately **defining the measurements** needed to create a well-proportioned, functional, and ergonomic product. The pattern must be **precise and detailed** to ensure it is easy to interpret during the following construction stages.

This model requires the creation of **two separate patterns**: one for the **outer fabric** and one for the **inner lining**.

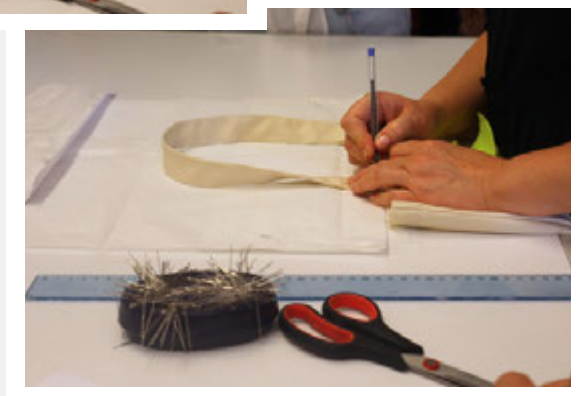
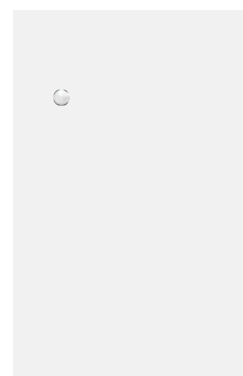
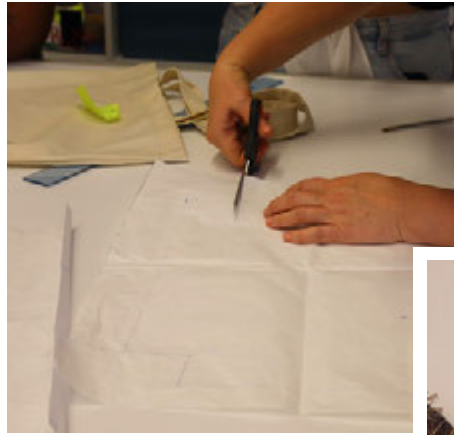

SILK SHOPPER 2



aracne

ADVOCATING THE ROLE
OF SILK ART AND CULTURAL
HERITAGE AT NATIONAL
AND EUROPEAN SCALE



STEP 2 Pattern placement

The placement phase is equally important. This step involves **positioning the pattern onto the fabric**, carefully following these steps:

- Lay the fabric flat, making sure it is free of wrinkles; if necessary, iron it beforehand.
- Pin the pattern securely onto the fabric to keep it stable during the tracing process.
- Trace the outline of each piece using tailor's chalk or a disappearing fabric pen.
- Leave a 2 cm seam allowance around each piece.

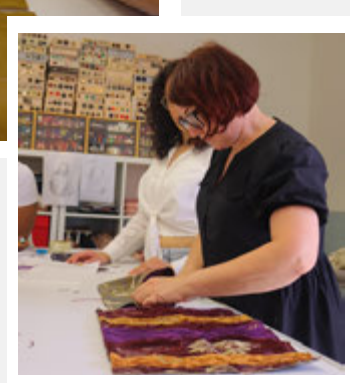
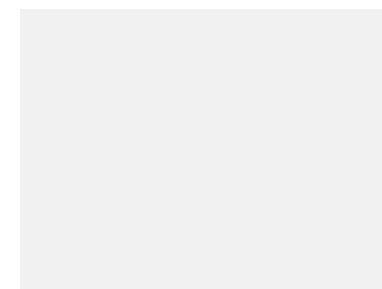
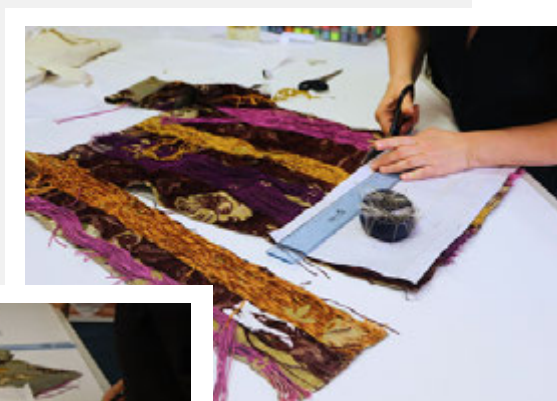
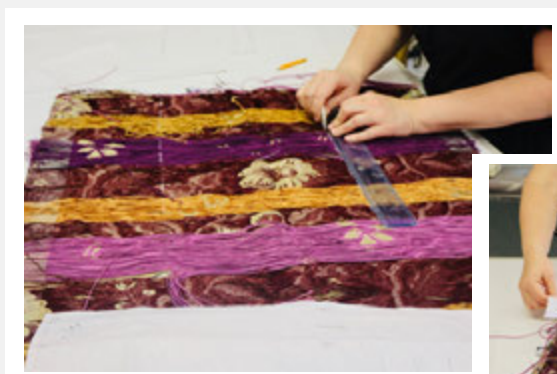

SILK SHOPPER 1



aracne

ADVOCATING THE ROLE
OF SILK ART AND CULTURAL
HERITAGE AT NATIONAL
AND EUROPEAN SCALE

STEP 3 Cutting and assembling

After the placement phase, it's time to **cut the pieces**.

Each individual piece is carefully cut and prepared for the assembly phase, which is more complex and requires time, precision, and attention to detail.

First, choose the appropriate cotton thread color and thickness, along with the correct sewing machine needle size, as each fabric requires a different gauge.

Now, the different parts of the bag **can be sewn**.

This shopper consists of **four elements**:

- a rectangular bottom part
- an upper part with a drawstring that serves as the closure
- an inner lining that includes the pocket
- the handles.

Begin by **creating the handles**: cut the pieces, press them with the help of a cardboard guide to shape them properly, then topstitch to assemble.

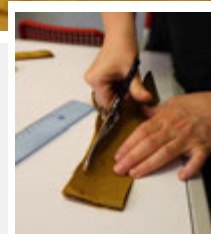
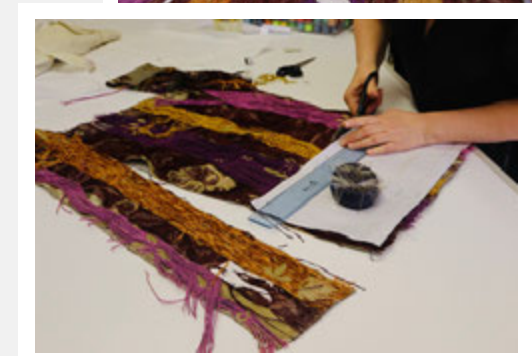
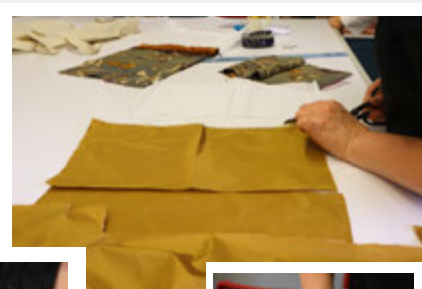
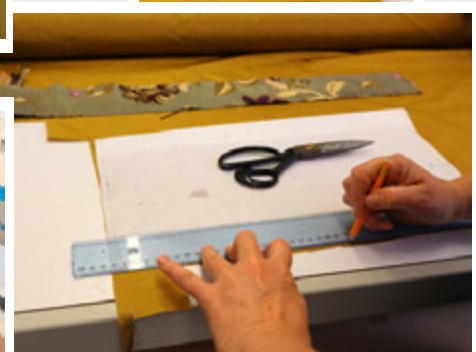
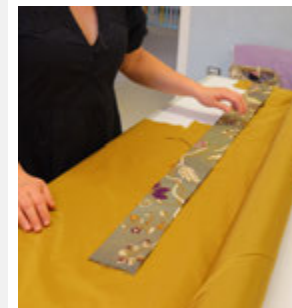
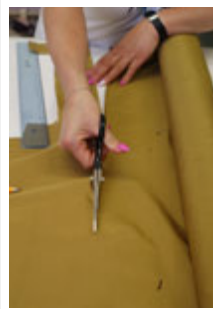
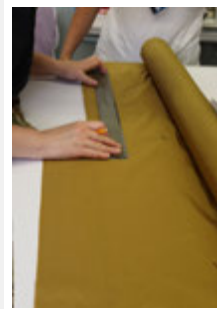

SILK SHOPPER 2



aracne

ADVOCATING THE ROLE OF SILK ART AND CULTURAL HERITAGE AT NATIONAL AND EUROPEAN SCALE

STEP 3

...

Proceed with the **top section** by sewing the sides, turning it right side out, and pressing.

Then fold the top edge to create a casing of at least 4 cm to **insert the drawstring** closure.

Before joining the two parts, **attach the lining** to the bottom section.

Then join the upper and lower parts with a visible seam, **incorporating part of the handles**.

This creates a practical **space between the handles** and the base of the bag—ideal for holding a rolled-up towel.

To finish, **insert two drawstrings** into the previously created channel.

The bag is now complete.

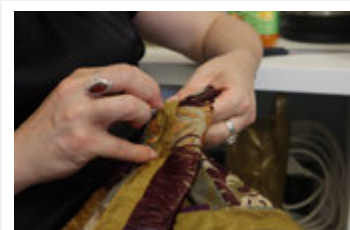
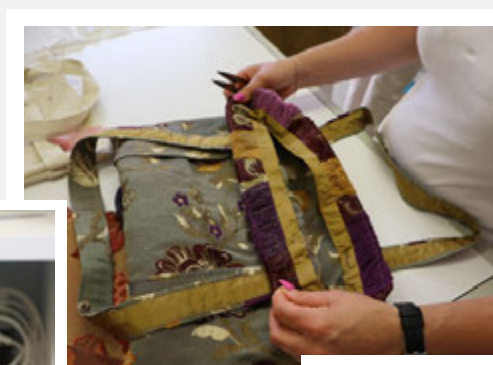
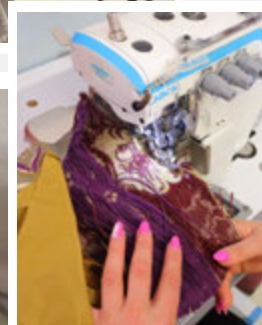
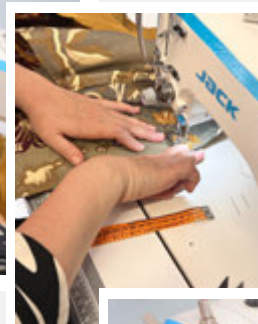

EVALab. Who we are

EVALab is an **ethical tailoring workshop** that provides specialized training and legal employment to **women who have survived male violence** and are seeking economic independence.

The workshop adopts **fair labor standards** that respect the pace and challenges of the women involved, offering a safe and supportive environment for professional growth.

Founded in 2020 in a **property confiscated from organised crime**, EVALab operates in an area marked by severe socio-economic and cultural hardship, with the aim of promoting legality, social inclusion, and local development.

All garments and accessories are **handmade using high-quality surplus fabrics** — particularly fine silks that reinterpret and innovate the textile traditions of **San Leucio**. The production process is environmentally conscious at every stage, focusing on sustainability, waste reduction, and reuse.

EVALab collaborates with leading institutions such as the Academy of Fine Arts of Naples, the San Carlo Theatre, and the Royal Palace of Caserta, as well as with companies like Gucci, which supports the workshop through its **Gucci Up** program by donating surplus fabrics for creative reuse with a strong social impact.

EVALab is an initiative of the social cooperative EVA, which operates in the Campania region managing four **anti-violence centres**, three women's **shelters**, and three **work reintegration projects** for women emerging from situations of violence — one of which is **EVALab** itself. The cooperative also runs a **nursery for children aged 0 to 3**, to support working mothers, and a **youth center** aimed at combating educational poverty and preventing gender based violence, welcoming girls and boys aged 6 to 17.

Some of these services are hosted in properties confiscated from organised crime and repurposed for social use — a concrete way of **promoting legality and local, sustainable development** in a region often known primarily for the presence of the Camorra.

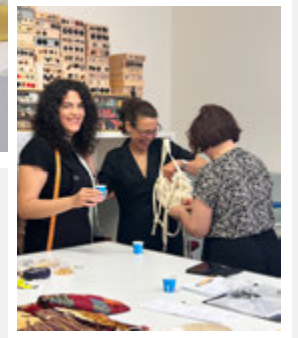

Some photos of the **EVALab** team with **Sonja Šterman** and **Andreja Rudolf**, lecturers from the University of Maribor, during the training organised as part of the Aracne project at EVALab headquarters from 2 to 6 June 2025, during which the **Silk Shopper 2** was finalised.

Contacts

EVALab project coordinator
Daniela D'Addio
d.daddio@cooperativaeva.com

EVA communication officer
Cristiana Scoppa
cristiana.scoppa@cooperativaeva.com

